

GP1 F31T/R, GP1 F32T/R, GP1 F33TT/RR/RT, GP1C321/321A/325

Light Transmitting /Receiving Units

■ Features

1. Low jitter (Atj : TYP. Ins)
2. High speed signal transmission
(8 Mbps, NRZ signal)
3. Directly connectable to modulation
/demodulation IC for digital audio equipment
 - Light transmitting unit ... Built-in light emitting diode driving circuit
 - Light receiving unit ... Built-in signal processing circuit
4. With two fixing holes for easy mounting on set panel
 - GP1 F32T/GP1F32R/GP1F33R/
(GP1 F33TT/33RT)
5. 2-channel type
(GP1 F33RR/GP1F33TT/GP1F33RT)

* We recommend you to use Sharp's optical fiber cable, (GP1C321, GP1C321A, GP1C325)

■ Applications

1. CD players
2. BS tuners
3. Digital amplifiers

■ Model Line-ups

Model No.	Internal Constitution
GP1F31T	Light transmitting unit
GP1F31R	Light receiving unit
GP1 F32T	Light transmitting unit
GP1F32R	Light receiving unit
GP1 F33TT	Dual light transmitting unit
GP1 F33RR	Dual light receiving unit
GP1F33RT	Light transmitting & receiving units
GP1C321	Optical fiber cable (1m)
GP1C321A	Optical fiber cable (0.6m)
GP1C325	Optical fiber cable (5m)

■ Outline Dimensions

(Unit : mm)

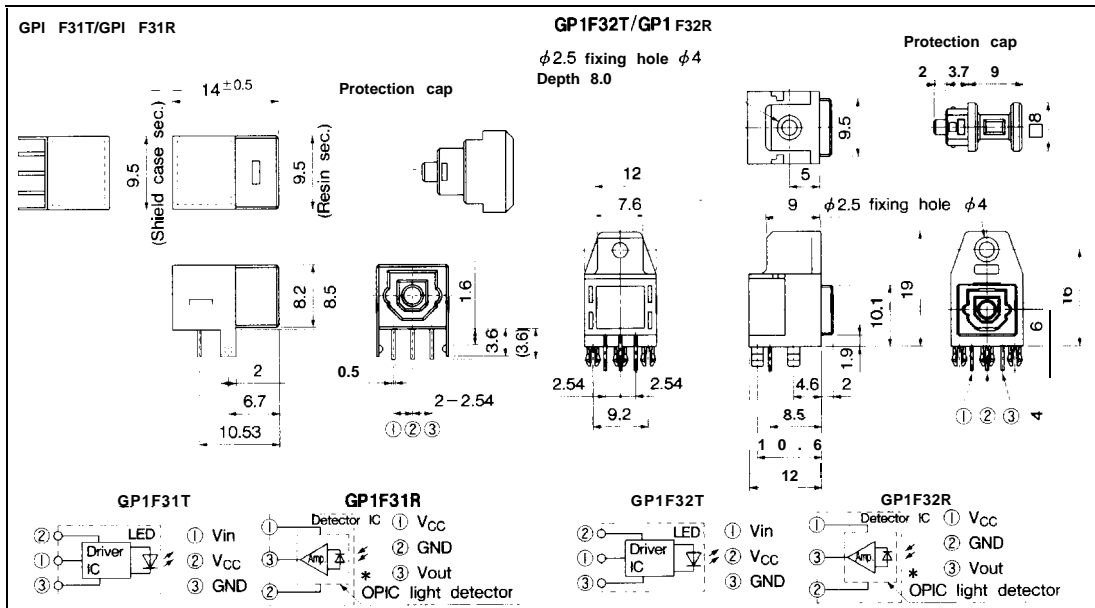

* OPIC is a trademark of Sharp and stands for Optical IC.

† has light detecting element- and signal processing circuitry integrated single chip.

Outline Dimensions

(Unit : mm)

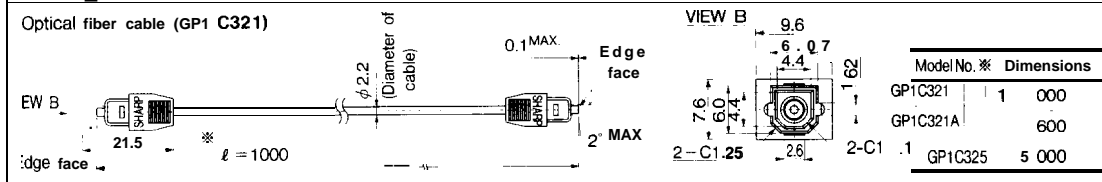
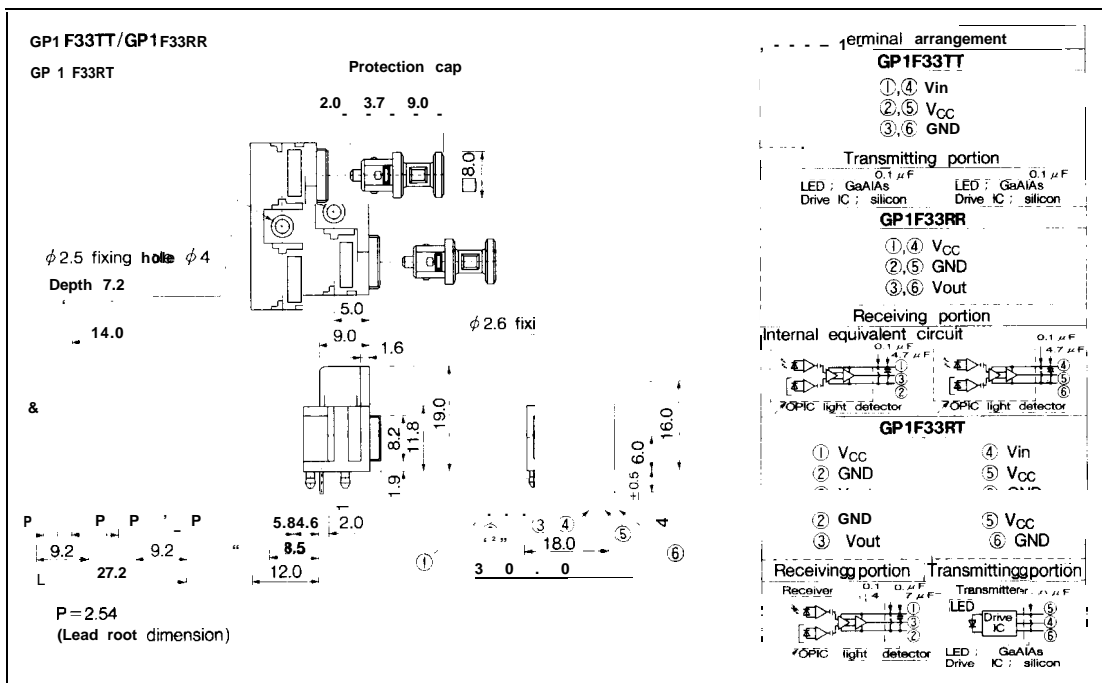

Absolute Maximum Ratings

Parameter	Symbol	Ratings	Unit
Supply voltage	V _{CC}	-0.5 to +7	v
Input voltage	*5 V _{in}	-0.5 to V _{CC} +0.5	V
*1 Power dissipation	*5 P	125	mW
*2 High level output current	*6 I _{OH}	4	mA
*3 Low level output current	*6 I _{OL}	4	mA
Operating temperature	T _{opr}	-20 to +70	°C
Storage temperature	T _{stg}	-30 to +80	°C
*4 Soldering temperature	T _{sol}	260	°C

- *1 At T_a = 25°C
- *2 Source current
- *3 Sink current
- *4 5 seconds/time up to 2 times
- *5 GP1F31T/GP1F32T/GP1F33TT/Transmitting portion of GP1F33RT
- *6 GP1F31R/GP1F32R/GP1F33RR/Receiving portion of GP1F33RT

Fiber cable (GP1C321, GP1C321A, GP1C325)

Parameter	Symbol	Rating	Unit
Tension	Plug & optical fiber	T _{pl}	40 N
	Optical fiber	T _f	40 N
Bending radius	R	25 Min.	mm
Operating temperature	T _{opr}	-30 to +70	°C
Storage temperature	T _{stg}	-30 to +70	°C

Fiber Optics

11

■ Electro-optical Characteristics

(1) Transmitter

GPI F31T/GPI F32T/GPI F331T/Transmitting portion of GP1F33RT

(Ta = 25°C)

Parameter	Symbol	Conditions	MIN.	TYP.	MAX.	Unit
Operating voltage	V _{CC}		4.75	5.00	5.25	V
Peak emission wavelength	λ _P		630	660	690	nm
Fiber coupling light output	P _C	*7	-21	-17	-15	dBm
Dissipation current	I _{CC}	*8	—	1	10	mA
High level input voltage	V _{IH}	*8	2			v
Low level input voltage	V _{IL}	*8	—	—	0.8	V
“Low→High” propagation delay time	t _{PLH}	*9	—	—	100	ns
“High→Low” propagation delay time	t _{PHL}	*9	—	—	100	ns
Pulse width distortion	Δ _{tw}	*9	-25(-30)**	—	-25(-30)**	ns
Jitter	Δ _{tj}	*10	—	1	25(30)**	ns
Operating transfer rate	T		—	—	8	Mbps

** Value in parenthesis : GP1F31T

(2) Receiver

GP1F31R/GP1F32R/GP1F33RR/Receiving portion of GP1F33RT

(Ta = 25°C)

Parameter	Symbol	Conditions	MIN.	TYP.	MAX.	Unit
Operating voltage	V _{CC}		4.75	5.00	5.25	v
Peak sensitivity wavelength	λ _P		—	700*	—	nm
Maximum input optical power level for receiving unit	P _{C MAX}	*11	-14.5	—	—	dBm
Minimum input optical power level for receiving unit	P _{C MIN}	*11	—	—	-24	dBm
Dissipation current	I _{CC}	*12	—	15	40	mA
High level output voltage	V _{OH}	*13	2.7	3.5	—	v
Low level output voltage	V _{OL}	*13	—	0.2	0.4	V
Rise time	t _r	*13	—	12	30	ns
Fall time	t _f	*13	—	4	30	ns
“Low→High” propagation delay time	t _{PLH}	*13	—	—	100	ns
“High→Low” propagation delay time	t _{PHL}	*13	—	—	100	ns
Pulse width distortion	A _{tw}	*13	-30	—	+30	OS
Jitter	A _{tj}	*14 P _C = -15dBm	—	1	30	ns
		NRZ. P _C = -24dBm	—	—	30	ns
Operating transfer rate	T	NRZ. duty 50% input	0.1	—	8	Mbps

*7 Measuring method of optical output coupling fiber

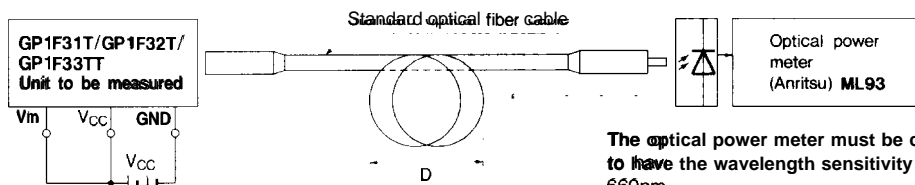

The optical power meter must be calibrated to have the wavelength sensitivity of 660nm.
(0dBm = 1 mW)

Note 1) $V_{CC} = 5.0 \pm 0.05$ V (Operating)

2) To bundle up the standard fiber cable, make it into a loop with the diameter (D) of 10cm or more.

*8 Input voltage /power dissipation measuring method

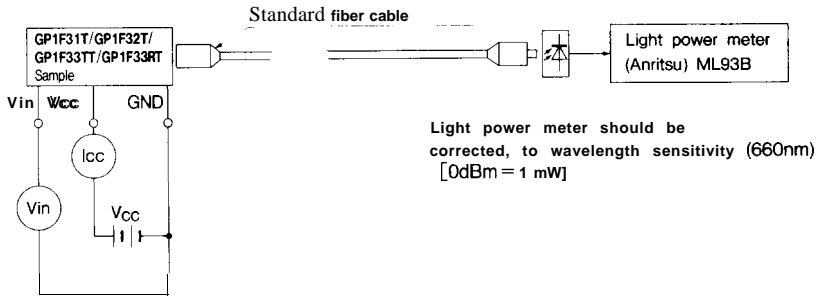

Input condition and measuring method

Input condition	Measuring method
$V_{in} = 2.0V$ or more	$-21 \leq P_c \leq -15dBm, I_{CC} = 10mA$ or less
$V_{in} = 0.8V$ or less	$P_c \leq -36dBm, I_{CC} = 10mA$ or less

Note (1) $V_{CC} = 5.0 \pm 0.05V$ (ON. State)

*9 Pulse response measuring method

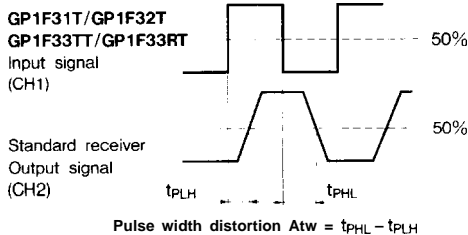
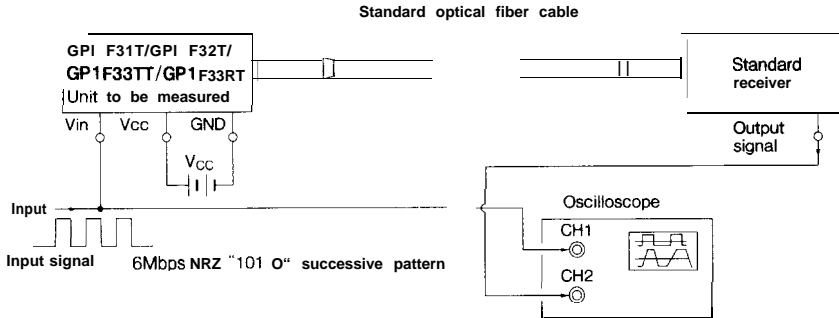

- Note 1) $V_{CC} = 5.0 \pm 0.05V$ (Operating)
- 2) The probe for the oscilloscope must be more than $1 M \Omega$ and less than $10pF$.

***10 Jitter measuring method**

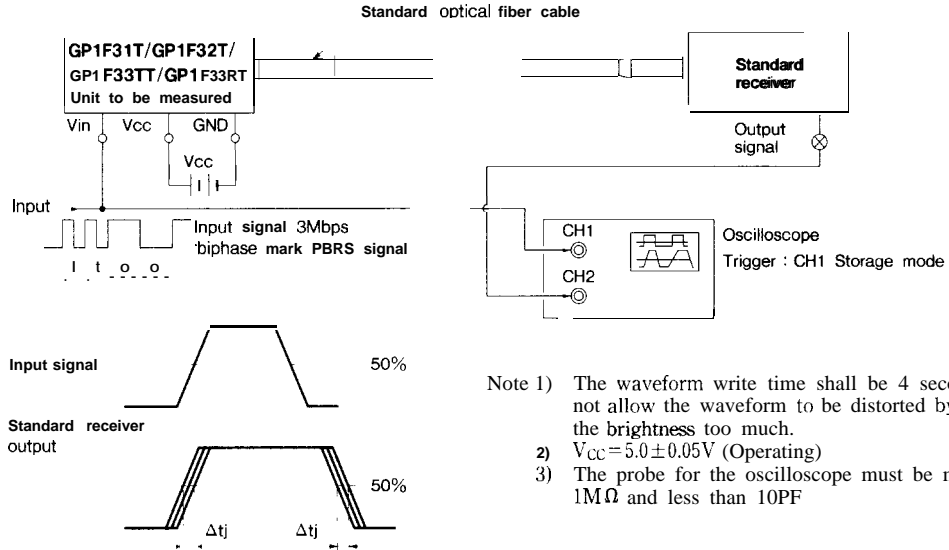

***11 Maximum input optical power level/Minimum input optical power level measuring method of receiving unit**

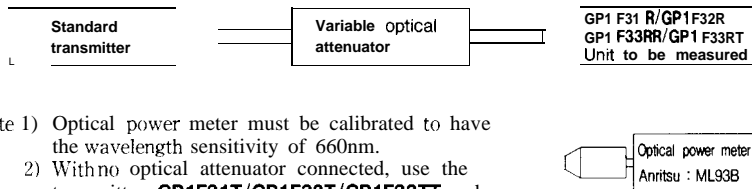

- Note 1) Optical power meter must be calibrated to have the wavelength sensitivity of 660nm.
2) With no optical attenuator connected, use the transmitter **GP1F31T/GP1F32T/GP1F33TT** and the optical fiber cable **GP1C321** with the fiber coupling light output set at $-15dBm/-24dBm$.

***12 Dissipation current measuring method**

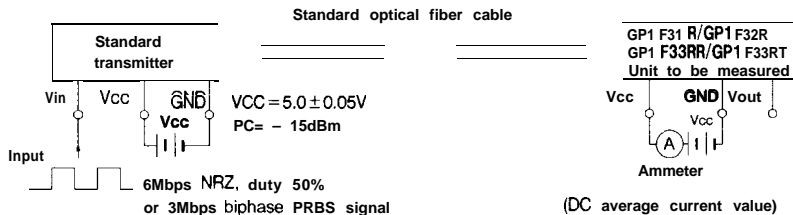

*13 output voltage/Pulse response measuring method

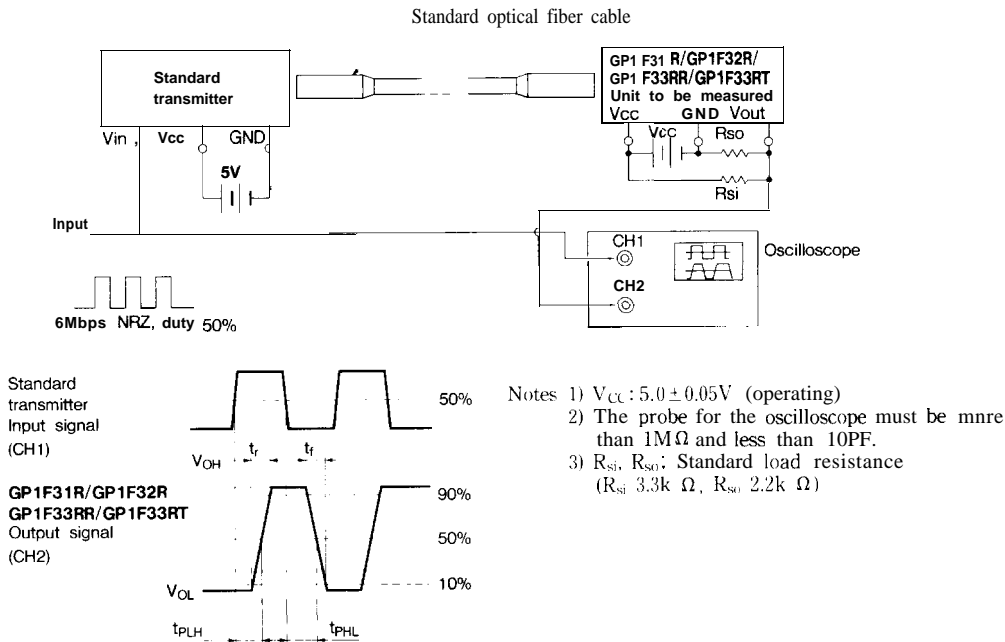

*14 Jitter measuring method

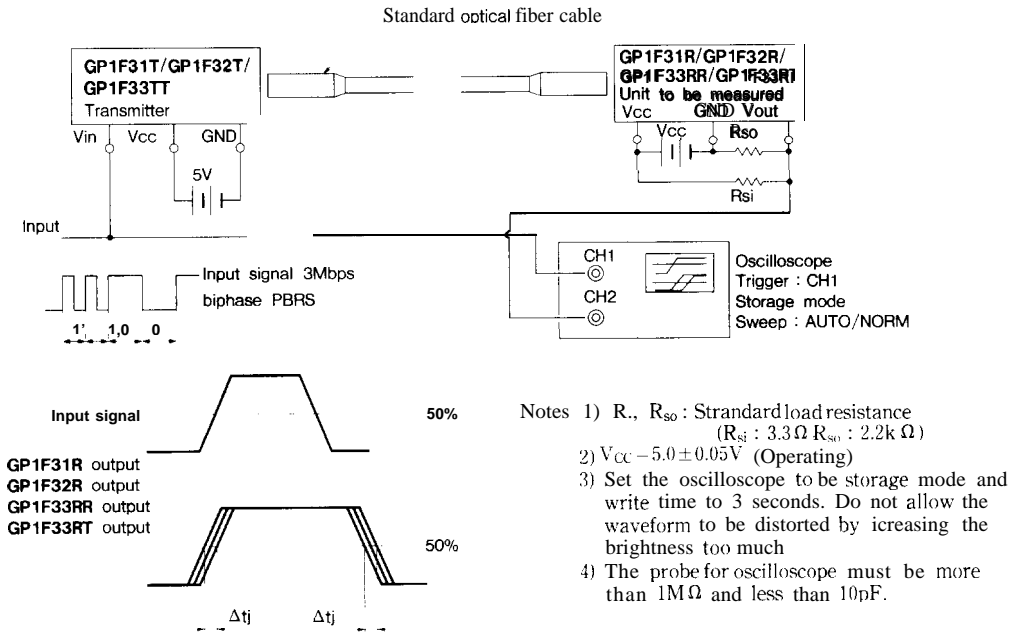

(3) Optical Fiber Cable

Parameter	Symbol	MIN.	TYP.	MAX.	Unit
Optical output coupling fiber	Pc	-17	-		dBm
Refracting ratio distribution	-	Step index			-

Measuring method for optical output coupling fiber

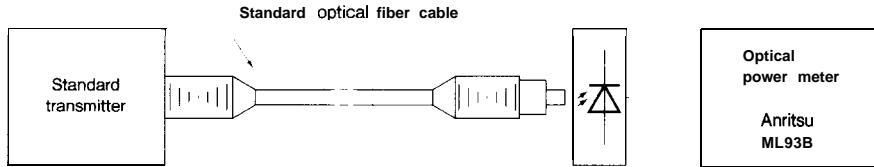

Standard light transmitter : Light transmitter that provides the fiber-end optical output of $-15\text{dBm} \pm 0.3\text{dBm}$ when the standard optical fiber cable is connected.

■ Mechanical Characteristics

Parameter	Symbol	Condition	MIN.	TYP.	MAX.	Unit
Inserting power disconnecting power		In compliance with EIAJ RC-5720 Initial value when a square connector is used.	6	-	40	N

■ System Configuration Example

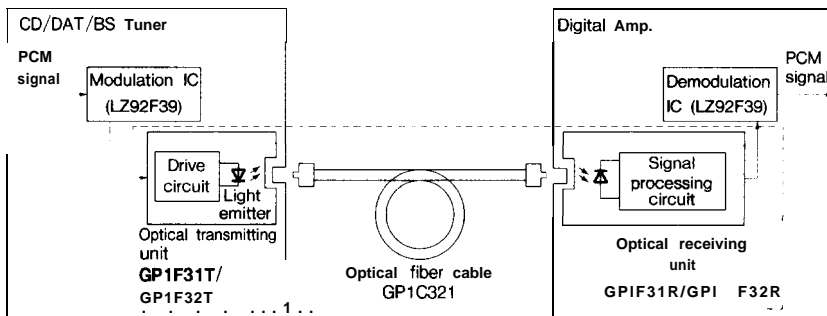

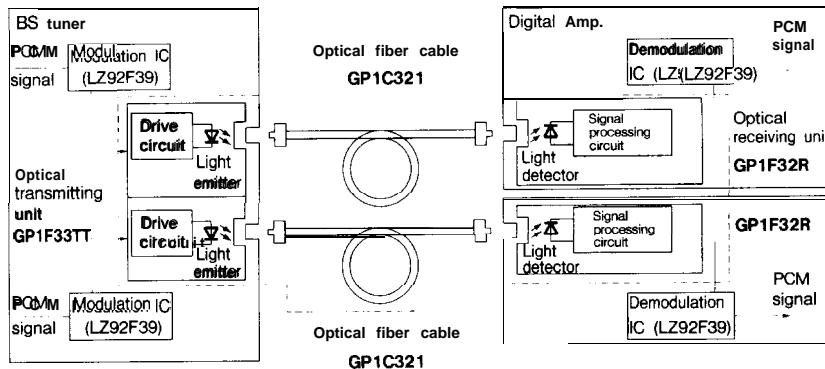

*LZ92F39 is Sharp's modulation/demodulation IC

In addition, you can also choose the following system configuration according to your application

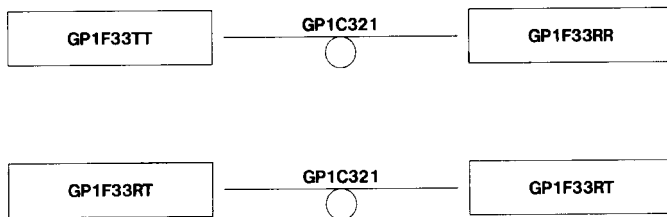

● please refer to the chapter “Precautions for Use” (Page 78 to 93).